

UPS12-490MR

**HIGH
RATE
MAX**



Valve Regulated Lead Acid Battery
Designed for UPS Standby Power Applications.

FEATURES & BENEFITS

APPLICATIONS

- Data Centers
- Network Operations Centers
- Industrial Process Control Facilities
- Internet Housing Sites
- Semiconductor Manufacturing
- Banks & Financial Markets
- Power Generation Plants
- Hospitals & Testing Laboratories
- Emergency 911 Response Centers

- 10 year design life @ 25°C
- Absorbent Glass Mat (AGM) technology for efficient gas recombination of up to 99% and freedom from electrolyte maintenance.
- 3 Year Warranty (refer Dynasty warranty card, 41-9027)
- Patented Long Life Alloy having the lowest calcium levels in the industry - minimizing grid growth, reducing gassing, and extending battery life.
- Patented UL Recognized Flame-arresting vents in each cell for safety and long life.
- Designed with the same recombination, thermal runaway prevention, gassing and flame retardant characteristics of the Bellcore 4228 compliant Dynasty Telecom products.
- Flame retardant polypropylene case and cover compliant with UL94-V2
- Proprietary Fixed Orifice Plate Pasting technology applying active materials on both sides of the grid for consistent cell-to-cell performance, higher capacity and uniform grid protection.
- Thermally welded case-to-cover bond to eliminate leakage.
- Can be operated in any orientation. Upright, side or end mounting recommended.
- Not restricted for air transport - Complies with IATA/ICAO Special Provisions A67.
- Not restricted for surface transport - Classified as non-hazardous material as related to DOT-CFR Title 49 parts 171-189.
- Not restricted for water transport - Classified as non-hazardous material per IMDG Amendment 27.

TECHNICAL DATA

Model	Voltage	AH 20 hr*	Constant Power Discharge Ratings - Watts per Cell @ 77°F (25°F)									Weight	
			Operating Time (in minutes) to 1.67 Volts per Cell									lbs	kg
			5	10	15	20	30	40	50	60	90		
UPS12-490MR	12	141	771	593	488	411	317	258	218	189	135	100.0	45.0

* Nominal 20 hr rate to 1.75 VPC in Ampere-Hours.

SPECIFICATIONS

Operating Temperature Range with temperature compensation	Discharge: -40°F (-40°C) to +160°F (71°C) Charge: -10°F (-23°C) to +140°F (60°C)
Nominal Operating Temperature Range	+74°F (23°C) to +80°F (27°C)
Recommended Maximum Charging Current Limit	C/5 amperes @ 20hr rate
Float Charging Voltage	13.65 ± 0.15 VDC average per 12V unit (6.75 to 6.90 per 6V unit)
Maximum AC Ripple (Charger)	0.5% RMS or 1.5% P-P of float charge voltage recommended for best results. Max voltage allowed = 1.4% RMS (4% P-P) Max current allowed = C/20
Self Discharge	Battery can be stored up to 6 months at 77°F (25°C) before a freshening charge is required. Batteries stored at temperatures greater than 77°F (25°C) will require recharge sooner than batteries stored at lower temperatures. See C&D brochure 41-7272, Self-Discharge and Inventory Control for details.
Equalize charge and cycle service voltage	14.40 to 14.80 VDC average per 12V unit @ 77°F (25°C) (7.20 to 7.40 VDC per 6V unit.)
Terminal: Flag	0.22 in. clearance hole to accept 0.1875 in. or 10-32 bolt (UPS12-100MR)
Terminal: Inserted	Threaded copper alloy insert terminal to accept 10-32 UNF bolt (UPS12-150MR, UPS12-210MR) ¼-20 UNC bolt (UPS12-300MR, UPS12-350MR, UPS12-400MR, UPS12-490MRLP, UPS12-490MR, UPS12-540MR, UPS6-620MR)
Terminal Hardware Annual Retorque	32 in.-lbs (3.48 N-m) (UPS12-100MR)
Terminal Hardware Initial Torque: Inserted Terminal	40 in.-lbs. (4.5 N-m) (UPS12-100MR) 30 in.-lbs. (3.4 N-m) (UPS12-150MR, UPS12-210MR) 110 in.-lbs. (12.4 N-m) (UPS12-300MR, UPS12-350MR, UPS12-400MR, UPS12-490MRLP, UPS12-490MR, UPS12-540MR, UPS6-620MR)

DIMENSIONS

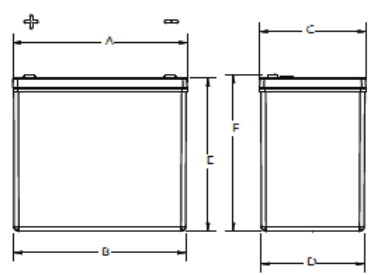

	A	B	C	D	E	F
UPS12-490MR	13.57	12.74	6.80	6.63	10.81	10.93
UPS12-540MR	(344.7)	(323.6)	(172.7)	(168.4)	(274.5)	(277.7)

UPS12-490MR/UPS12-540MR

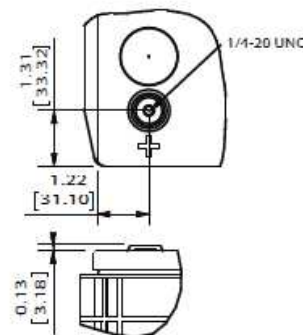

*All dimensions in inches (mm). All dimensions are for reference only. Contact a C&D Representative for complete dimension information.
NOTE: Batteries to be mounted with 0.5 in (1.25 cm) spacing minimum and free air ventilation.

UPS12-490MR

Constant Power Discharge Ratings - Watts Per Cell @ 77° F (25° C)										
Operating Time to End Point Voltage (in minutes)										
End Point Volts/Cell	5	10	15	20	30	40	45	50	60	90
1.75	655	527	443	382	300	247	227	210	183	132
1.70	740	573	470	400	310	253	233	215	187	134
1.67	771	593	488	411	317	258	237	218	189	135
1.65	799	614	497	419	321	261	239	220	191	137
1.60	838	640	513	429	325	264	241	222	193	138

Constant Current Discharge Ratings - Amperes @ 77° F (25° C)										
Operating Time to End Point Voltage (in hours)										
End Point Volts/Cell	1	2	3	5	8	10	12	20	24	72
1.85	80.8	48.4	34.8	22.4	15.0	12.3	10.5	6.66	5.64	1.93
1.80	86.4	51.3	36.7	23.4	15.6	12.7	10.8	6.88	5.82	1.99
1.75	91.0	53.5	38.2	24.4	16.2	13.1	11.1	7.06	5.98	2.03

Note: Batteries to be mounted with 0.5 in. (1.25 cm) spacing minimum and free air ventilation. Specifications subject to change without notification. Above ratings do not include interunit connector voltage drops.

SPECIFICATIONS

Model	Cells per Unit	Maximum Discharge Current (AMPS)	Short Circuit Current (AMPS @ 0.1 sec)	Ohms Impedance 60 Hz (Ω)
UPS12-490MR	6	800	5000	0.0023

High Rate Max Part Number	Manufacturer Approved Premium Replacement for:
UPS12-100MR	UPS12-100FR
UPS12-150MR	UPS12-140FR & MR12-150
UPS12-210MR	UPS12-170FR, UPS12-200FR & MR12-210
UPS12-300MR	UPS12-270FR & MR12-300
UPS12-350MR	UPS12-310FR & MR12-350
UPS12-400MR	UPS12-370FR & MR12-400
UPS12-490MRLP	UPS12-475FR, MR12-490 & UPS12-490MR (Low profile high rate applications)
UPS12-490MR	UPS12-475FR & MR12-490 (Extended run applications)
UPS12-540MR	UPS12-530FR & MR12-540
UPS6-620MR	UPS6-620FR

C&D TECHNOLOGIES, INC.

1400 Union Meeting Road
P.O. Box 3053 • Blue Bell, PA 19422-0858
(215) 619-2700 • Fax (215) 619-7899 • (800) 543-8630
customersvc@cdtechno.com
www.cdtechno.com

Any data, descriptions or specifications presented herein are subject to revision by C&D Technologies, Inc. without notice. While such information is believed to be accurate as indicated herein, C&D Technologies, Inc. makes no warranty and hereby disclaims all warranties, express or implied, with regard to the accuracy or completeness of such information. Further, because the product(s) featured herein may be used under conditions beyond its control, C&D Technologies, Inc. hereby disclaims all warranties, either express or implied, concerning the fitness or suitability of such product(s) for any particular use or in any specific application or arising from any course of dealing or usage of trade. The user is solely responsible for determining the suitability of the product(s) featured herein for user's intended purpose and in user's specific application.